

GF 5100 HINGED (GFRG) PANEL

FOR CEILINGS

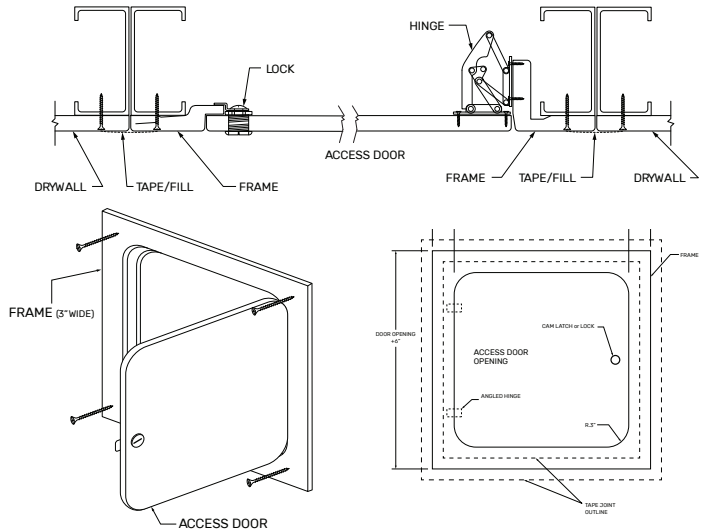
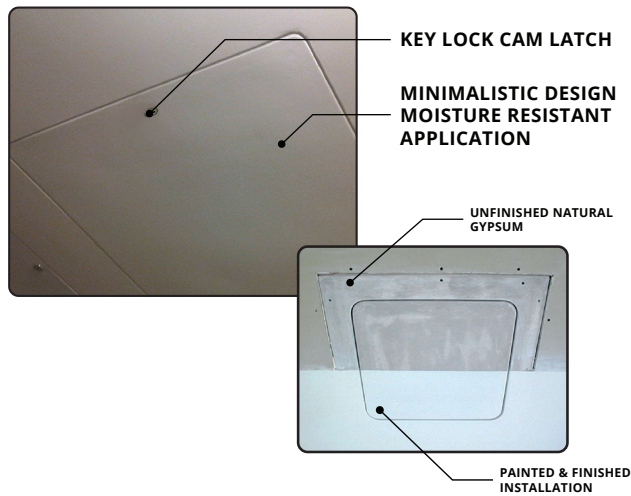

MSDS: Per OSHA HazCom per 29 CFR 1910.1200(b)(6)(iv): "Article" means a manufactured item other than a fluid or particle: (i) which is formed to a specific shape or design during manufacture; (ii) which has end use function(s) dependent in whole or in part upon its shape or design during end use; and (iii) which under normal conditions of use does not release more than very small quantities, e.g., minute or trace amounts of a hazardous chemical (as determined under paragraph (d) of this section), and does not pose a physical hazard or health risk to employees.

PRODUCT DETAILS

CONSTRUCTION

Door & Trim: Glass Fiber Reinforced Gypsum (GFRG) based design can't rust and blends seamlessly with new or retrofitted drywall ceilings. The panel ensures that your aesthetic style is noticed, and not your access panels.

Finish: Unpainted natural GFRG. Paintable surface.

Hinge & Latch: Concealed hinges and key lock cam latch.

Gasket: Gasketed on 4 sides of Neoprene/EPDM/SBR. Meets ASTM D 1056/ SCE 41, RE 41, 2A1/ substrate UL 94HF 1 recognized.

Ceiling Installation: Access panels installed with standard supplies: screws are #6 buglehead, and joints use standard tape and joint compound. Substrate material is determined by the job site.

Physical Properties: 1/8" to 3'16" shell thickness, fastener test pull out (wood studs: 525 lbs. avg. and metal studs: 215 lbs. avg.). Fasteners push thru test: 350 lbs avg. Fuel Contribution (ASTM E84 80):0. Flame spread (ASTM E84 80): 0, Combustion (ASTM E84 80): non combustible. Non rated.

DURABILITY

Glass Fiber Reinforced Gypsum (GFRG) ceiling panel, specified for residential and commercial applications where discreet, concealed access is desired.



SEE BACK OF SHEET FOR PRODUCT SIZES AND OPTIONS ►

PRODUCT SIZES

GF 5100 HINGED (GFRG) PANEL

X	Model Number	Door Size W x H	Wall Opening	Ship Wt. Lbs.
	GF 5100	9 x 9	15 x 15	2.5
	GF 5100	12 x 12	18 x 18	5
	GF 5100	16 x 16	22 x 22	8.5
	GF 5100	18 x 18	24 x 24	10
	GF 5100	24 x 24	30 x 30	13
	GF 5100	30 x 30	36 x 36	15

OPTIONS

Gasket:

- Gasketed on 4 sides of Neoprene
 EPDM:SBR. Meets ASTM D 1056: SCE 41, RE 41, 2A1: substrate UL 94HF 1 recognized

Custom Size: _____

Project: _____	Date: _____
Contractor: _____	Architect: _____
Sizes: _____	Quantity: _____
	App Initials: _____